

# TRIJENA

## STAGE 15 STREETSAPES

PROJECT NUMBER: 304018  
 LANDSCAPE ARCHITECTURE DRAWINGS  
 FOR PGG(MICKLEHAM) PTY LTD

### DRAWING SCHEDULE

DRAWING NO.	DESCRIPTION	SHEET NO.	REVISION
LD100	COVER - SHEET 1	1	F
LD700	PLANTING PLANS - SHEET 1	2	F
LD701	PLANTING PLANS - SHEET 2	3	F
LD900	DETAILS - SHEET 1	4	F

PLANTING SCHEDULE					
TREES					
CODE	BOTANICAL NAME	COMMON NAME	INSTALL SIZE	MATURE SIZE (h x w)	QTY
An	<i>Acer negundo</i> 'Sensation'	BOX ELDER	45L	9 x 6	10
Ac	<i>Angophora costata</i>	SMOOTH-BARKED APPLE	45L	30 x 10	16
Em	<i>Eucalyptus leucoxylon</i> 'Megalocarpa'	LARGE FRUITED YELLOW GUM	45L	11 x 6	27
Pc	<i>Pyrus calleryana</i> 'Chanticleer'	ORNAMENTAL PEAR	45L	8 x 6	3
Total					56

GARDEN BED PLANTING MIX							
Installed size: Tubestock					Location	G1a	G1b
					Area m <sup>2</sup>	48	38
BOTANICAL NAME	COMMON NAME	Species Density m <sup>2</sup>	% Distribution Species	Total No. of Plants			
<i>Correa glabra</i> 'Ivory Lantern'	Rock Correa	2	20	86	48	38	
<i>Lomandra longifolia</i> 'Tanika'	Lomandra 'Tanika'	4	80	172	96	76	
Total				100	258		

NOTE: No plants are to be planted within 1m of tree trunks.  
**ALL TREE STOCK TO CONFORM TO AS 2303:2018; APPENDIX D.**  
**ALL TREE STOCK OF 45L TO HAVE A HEIGHT OF 1.5m - 2.0m AND CALIPER OF 25mm - 30mm**  
**UNLESS APPROVED IN WRITING BY THE SUPERINTENDENT**

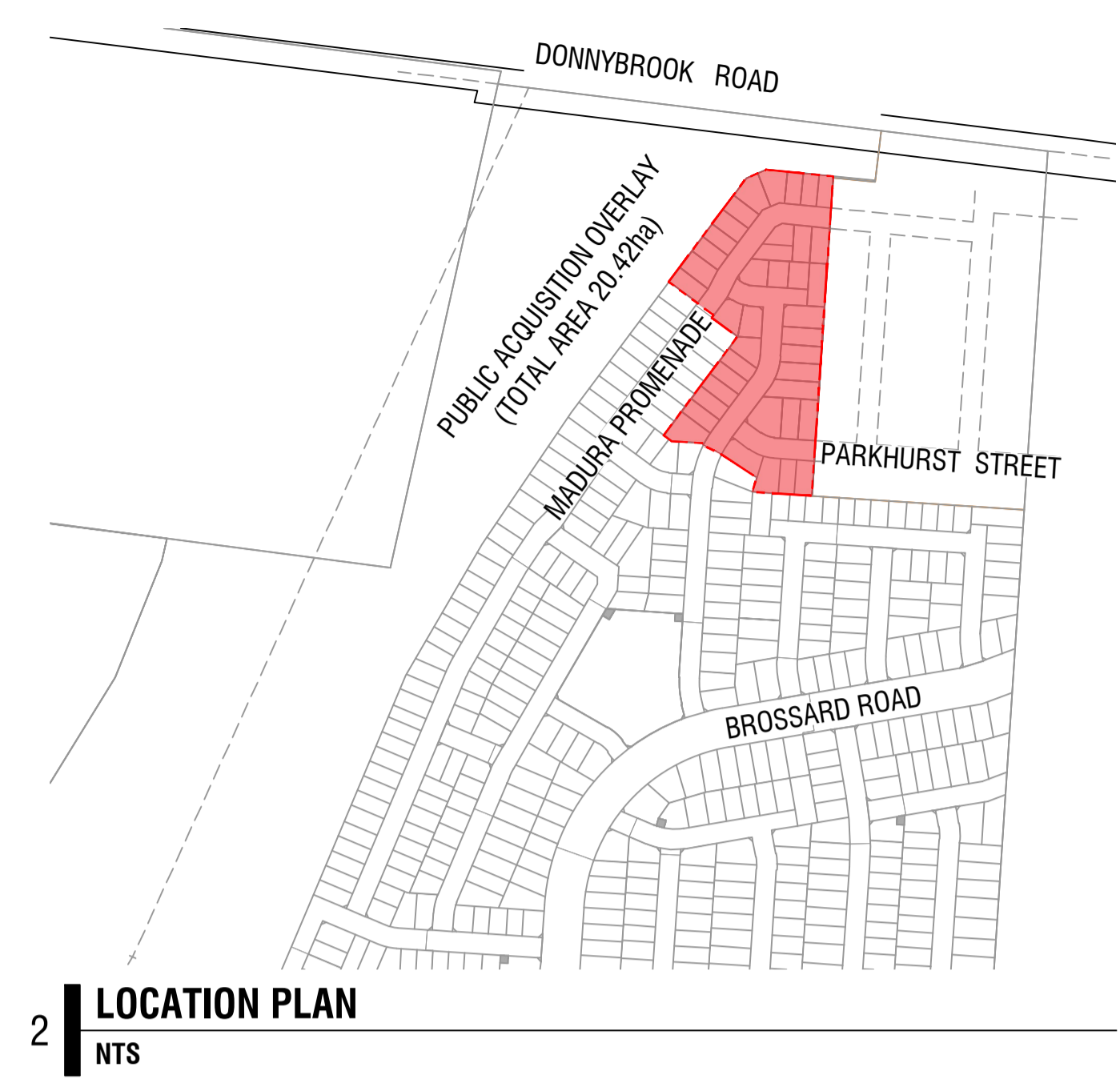

2 LOCATION PLAN  
NTS



1 TRIJENA STAGE 15 STREETSAPES  
Scale 1:1000 @ A1

### GENERAL NOTES

- Unless otherwise specified on the drawings all measurements, lengths, heights and distances to be determined from dimensions and NOT scaled off the drawings.
- Before commencement of any works it is the responsibility of the Landscape Contractor to contact Dial Before You Dig 1100 (Fax 1300 652 077) for information on services in the area shown on the plan (www.dialbeforeyoudig.com.au)
- The locations of underground services are approximate only and their exact position should be proven on site. No guarantee is given that all existing services are shown. The Contractor shall verify the location and depth of all services prior to commencing on site.
- The Contractor must have a copy of Melbourne One Call/Services information and plans on site at all times.
- The Contractor shall be liable for any damage to services during landscape works.
- All trees shall be planted in locations shown on this plan, with set out to be approved on site by the Superintendent prior to planting.
- Tree canopies are shown at 75% of mature diameter.
- Any change in plant species must have the approval of the Superintendent.
- Trees shall not be planted less than the following distances from existing elements, unless otherwise stated in the documentation:
  - Pedestrian pathways - 1.2m
  - Pedestrian pathways in reserve - 2.0m
  - Driveways and crossovers - 3.0m
  - Stormwater and sewerage pits - 2.0m
  - Intersections - 10.0m
  - Service crossings - 2.0m
  - Back of Kerb - 1.0m min.
  - Street lights and power poles - 4.0m
  - Service assets, incl. junction boxes, pits etc - 2.0m
  - Fire plugs - 3.0m
- The Superintendent is to inspect trees supplied by the Contractor prior to planting.
- The Principal will ensure that all property boundaries are to be pegged out by licensed surveyors prior to set out of landscape works.
- All drawings 'For Construction' to be printed in colour.
- All tree stock to conform to as 2303:2018; Appendix D.



© Spiire Australia Pty Ltd All Rights Reserved  
 This document is produced by Spiire Australia Pty Ltd solely for the benefit of and use by the client in accordance with the terms of the retainer. Spiire Australia Pty Ltd does not and shall not assume any responsibility or liability whatsoever to any third party arising out of any use or reliance by third party on the content of this document.

L6 414 LA TROBE STREET PO BOX 16084 MELBOURNE  
 VICTORIA 8007 AUSTRALIA T 61 3 9993 7888  
 www.spiire.com.au ABN 55 050 029 635

### CONSTRUCTION

REV	DESCRIPTION	APP	DATE
F	ISSUED FOR CONSTRUCTION	MB	07/07/22
E	ISSUED FOR APPROVAL	MB	05/07/22
D	ISSUED FOR APPROVAL	MB	27/06/22
C	ISSUED FOR APPROVAL	MB	21/06/22
B	ISSUED FOR APPROVAL	MB	21/04/22
A	PRELIMINARY ISSUE	MB	10/01/22

### TRIJENA

STAGE 15 STREETSAPES  
 DETAILED DESIGN  
 COVER - SHEET 1  
 SHEET 1 OF 4  
 HUME CITY COUNCIL  
 PGG(MICKLEHAM) PTY LTD









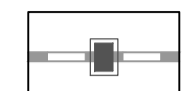

MGA 94 ZONE 1:1000 SCALE @ A1

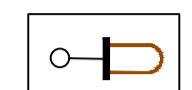
DESIGNED	DRAWN	CHECKED	APPROVED
BM	BM	GV	MB

DATE	DRG NO.	REV
10/01/2022	304018LD100	F

file name: 304018LD100.dwg layout name: LD100 plotted by: Matthew Bradford  
 file location: G:\304018 Landscape\ACAD plant date: 07/2022 2:01 PM Sheet 1 of 4 Sheets

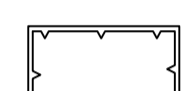
**LEGEND**

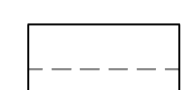
-  EXTENT OF WORKS
-  EXISTING STORMWATER  
By others / refer Civil
-  EXISTING CONDUITS / SERVICES  
By others / refer Civil
-  EXISTING STREET LIGHTS  
Refer Power
-  STREET TREE  
Refer Schedules, Details and Specification
-  GRASS - HYDROSEED  
Refer Details and Specification
-  GRASS - INSTANT TURF  
Refer Details and Specification
-  3M ELECTRICAL JOINT AND  
CONDUIT END OFFSET
-  4M LIGHT POLE AND  
PARALLELING PILLAR OFFSET
-  GARDEN BED  
Refer Schedules, Details and Specification
-  BOLLARDS  
By Civil
-  SPADE EDGING  
Refer Schedules, Details and Specification

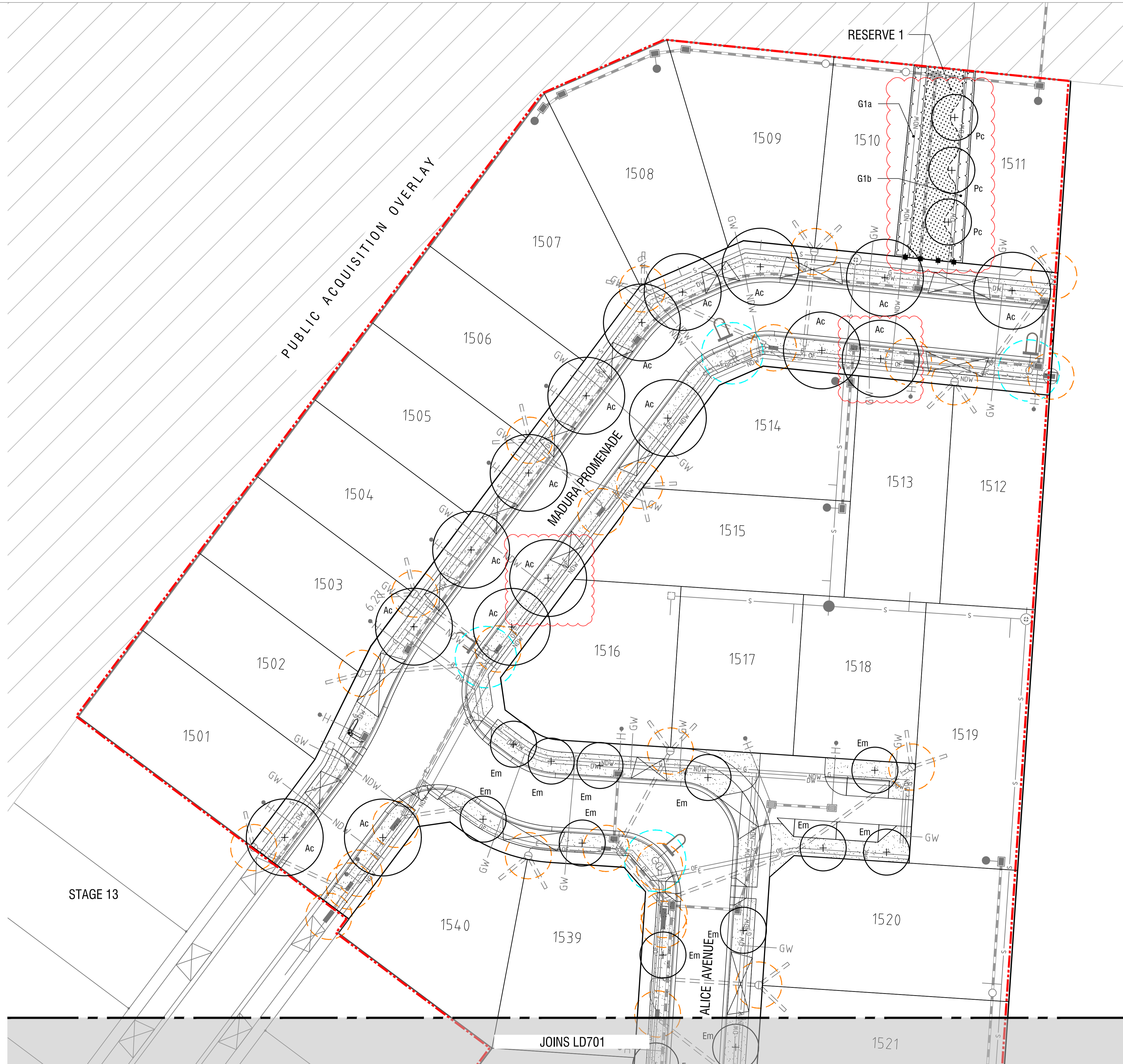

**NOTES**

**spiire**

© Spiire Australia Pty Ltd All Rights Reserved  
 This document is produced by Spiire Australia Pty Ltd solely for the benefit of and use by the client in accordance with the terms of the retainer. Spiire Australia Pty Ltd does not and shall not assume any responsibility or liability whatsoever to any third party arising out of any use or reliance by third party on the content of this document.

**L6 414 LA TROBE STREET PO BOX 16084 MELBOURNE  
 VICTORIA 8007 AUSTRALIA T 61 3 9993 7888**  
 www.spiire.com.au ABN 55 050 029 635

**CONSTRUCTION**





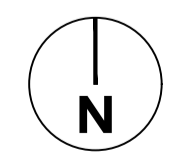
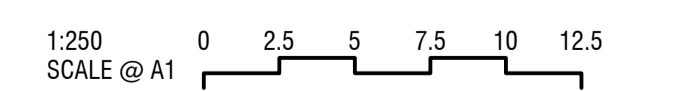

F	ISSUED FOR CONSTRUCTION	MB	07/07/22
E	ISSUED FOR APPROVAL	MB	05/07/22
D	ISSUED FOR APPROVAL	MB	27/06/22
C	ISSUED FOR APPROVAL	MB	21/06/22
B	ISSUED FOR APPROVAL	MB	21/04/22
A	PRELIMINARY ISSUE	MB	10/01/22
REV	DESCRIPTION	APP	DATE

**TRIJENA**  
**STAGE 15 STREETSCAPES**  
**DETAILED DESIGN**  
 PLANTING PLANS - SHEET 1  
 SHEET 2 OF 4  
 HUME CITY COUNCIL  
 PGG(MICKLEHAM) PTY LTD

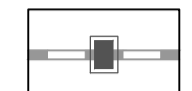
  
 MGA 94 ZONE  
 1:250 SCALE @ A1  
  
 DESIGNED **BM** DRAWN **BM** CHECKED **GV** APPROVED **MB**  
 DATE **10/01/2022** DRG NO. **304018LD700** REV **F**

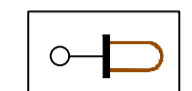
file name: 304018LD700.dwg layout name: LD700 plotted by: Matthew Bradford  
 file location: C:\304018\Landscapes\ACAD plant date: 07/2022 2:01 PM Sheet 2 of 4 Sheets

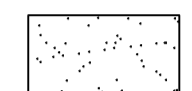
**LEGEND**

-  EXTENT OF WORKS
-  EXISTING STORMWATER  
By others / refer Civil
-  EXISTING CONDUITS / SERVICES  
By others / refer Civil
-  EXISTING STREET LIGHTS  
Refer Power
-  STREET TREE  
Refer Schedules, Details and Specification
-  GRASS - HYDROSEED  
Refer Details and Specification
-  3M ELECTRICAL JOINT AND  
CONDUIT END OFFSET
-  4M LIGHT POLE AND  
PARALLELING PILLAR OFFSET

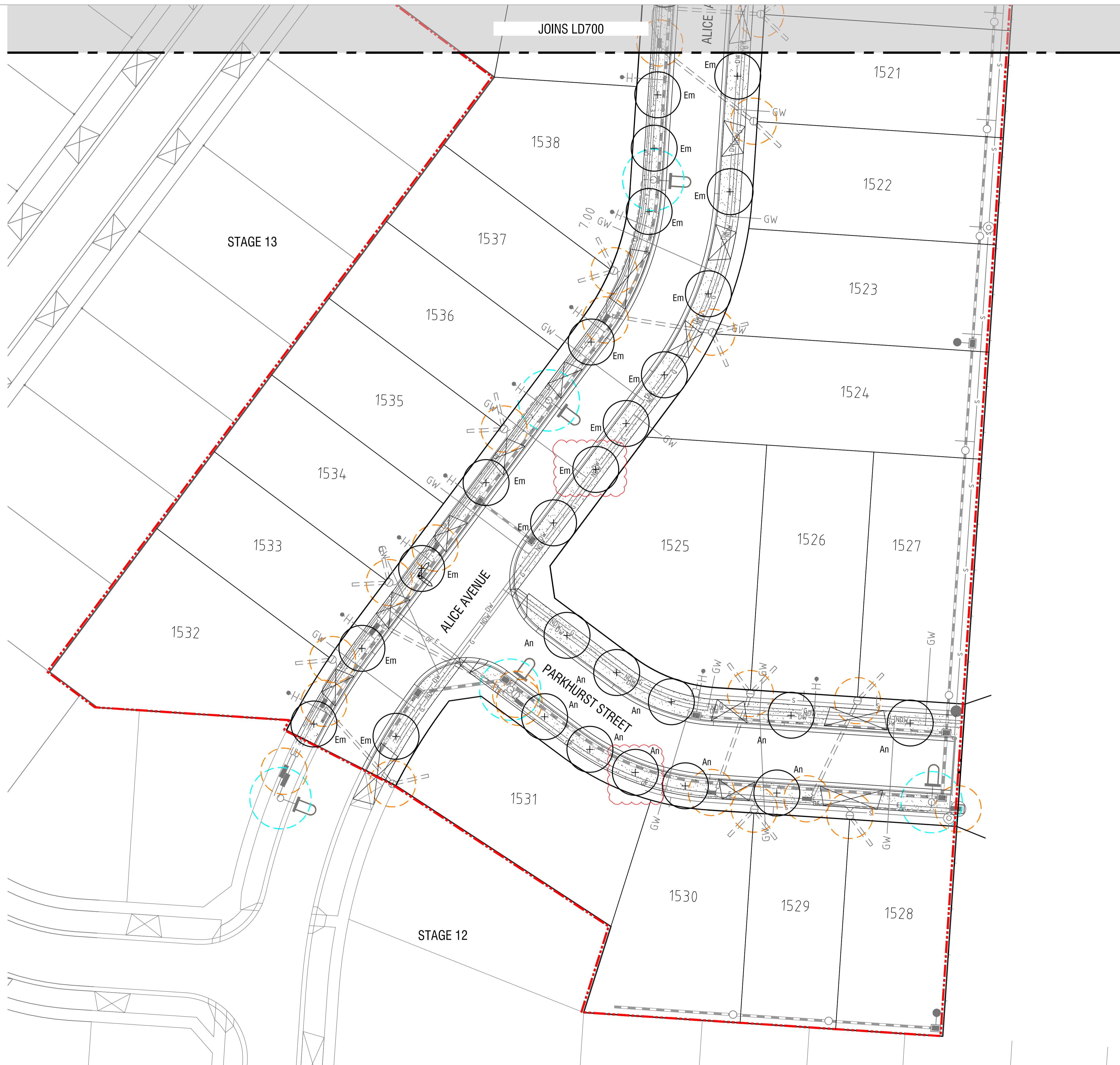

**NOTES**



© Spiire Australia Pty Ltd All Rights Reserved  
 This document is produced by Spiire Australia Pty Ltd solely for the benefit of and use by the client in accordance with the terms of the retainer. Spiire Australia Pty Ltd does not and shall not assume any responsibility or liability whatsoever to any third party arising out of any use or reliance by third party on the content of this document.

**L6 414 LA TROBE STREET PO BOX 16084 MELBOURNE  
 VICTORIA 8007 AUSTRALIA T 61 3 9993 7888**  
 www.spiire.com.au ABN 55 050 029 635

**CONSTRUCTION**

F	ISSUED FOR CONSTRUCTION	MB	07/07/22
E	ISSUED FOR APPROVAL	MB	05/07/22
D	ISSUED FOR APPROVAL	MB	27/06/22
C	ISSUED FOR APPROVAL	MB	21/06/22
B	ISSUED FOR APPROVAL	MB	21/04/22
A	PRELIMINARY ISSUE	MB	10/01/22
REV	DESCRIPTION	APP	DATE

**TRIJENA  
 STAGE 15 STREETSCAPES  
 DETAILED DESIGN  
 PLANTING PLANS - SHEET 2  
 SHEET 3 OF 4  
 HUME CITY COUNCIL  
 PGG(MICKLEHAM) PTY LTD**

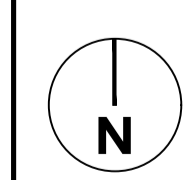
 MGA 94 ZONE 1:250 SCALE @ A1

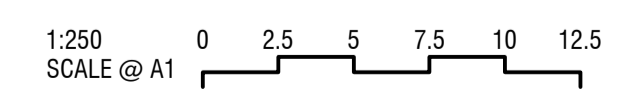

DESIGNED	DRAWN	CHECKED	APPROVED
BM	BM	GV	MB
DATE	DRG NO.	REV	
10/01/2022	304018LD701	F	

file name: 304018LD700.dwg layout name: LD701 plotted by: Matthew Bradford  
 file location: C:\30394\18\Landscapes\ACAD plant date: 07/07/2022 2:01 PM Sheet 3 of 4 Sheets

file name: 304018LD900.dwg layout name: LD900 created by: Matthew Bradford  
file location: C:\304018\Landscapes\ACAD plant.dwg date: 07/2022 2:01 PM Sheet 4 of 4 Sheets

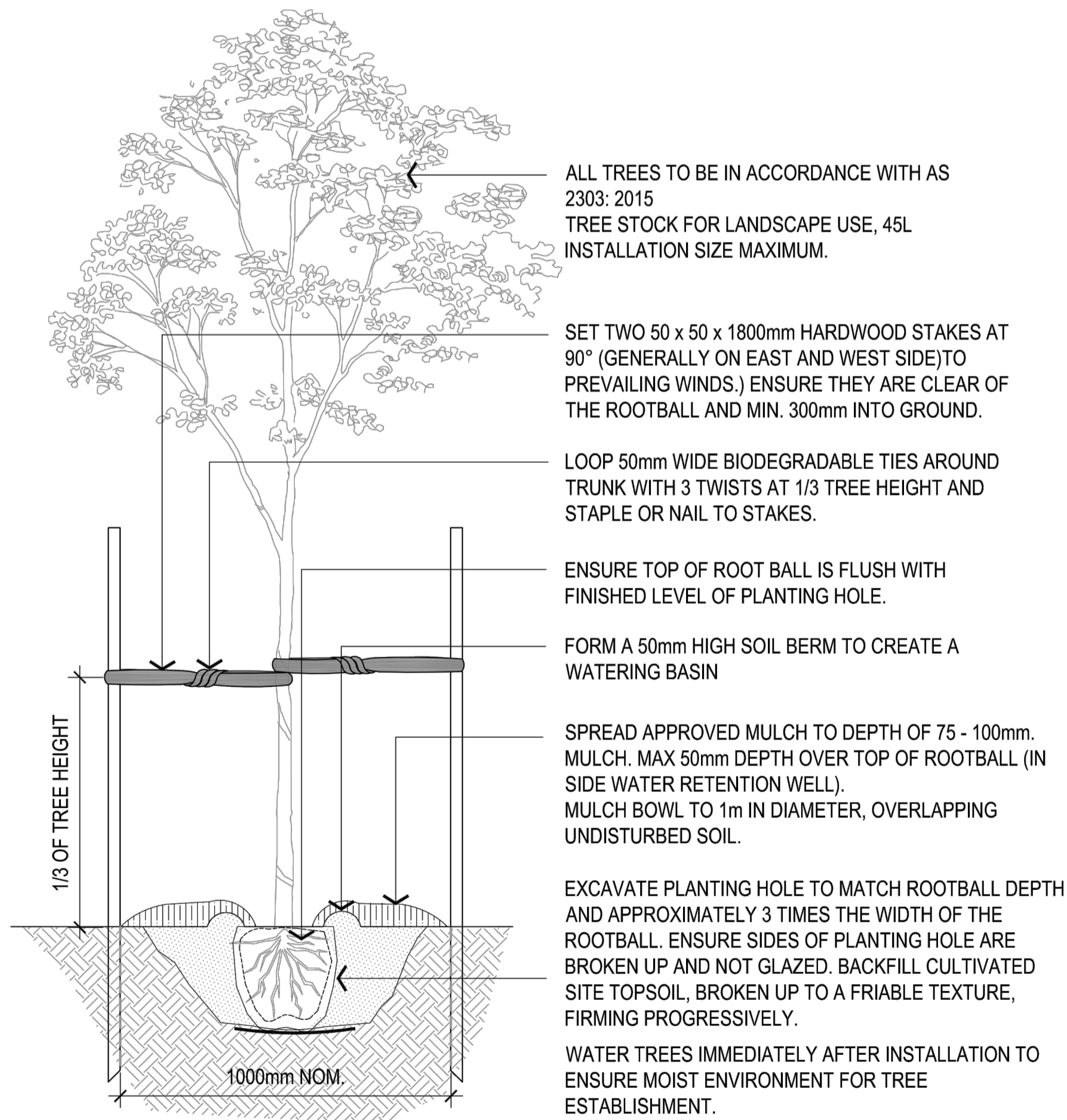
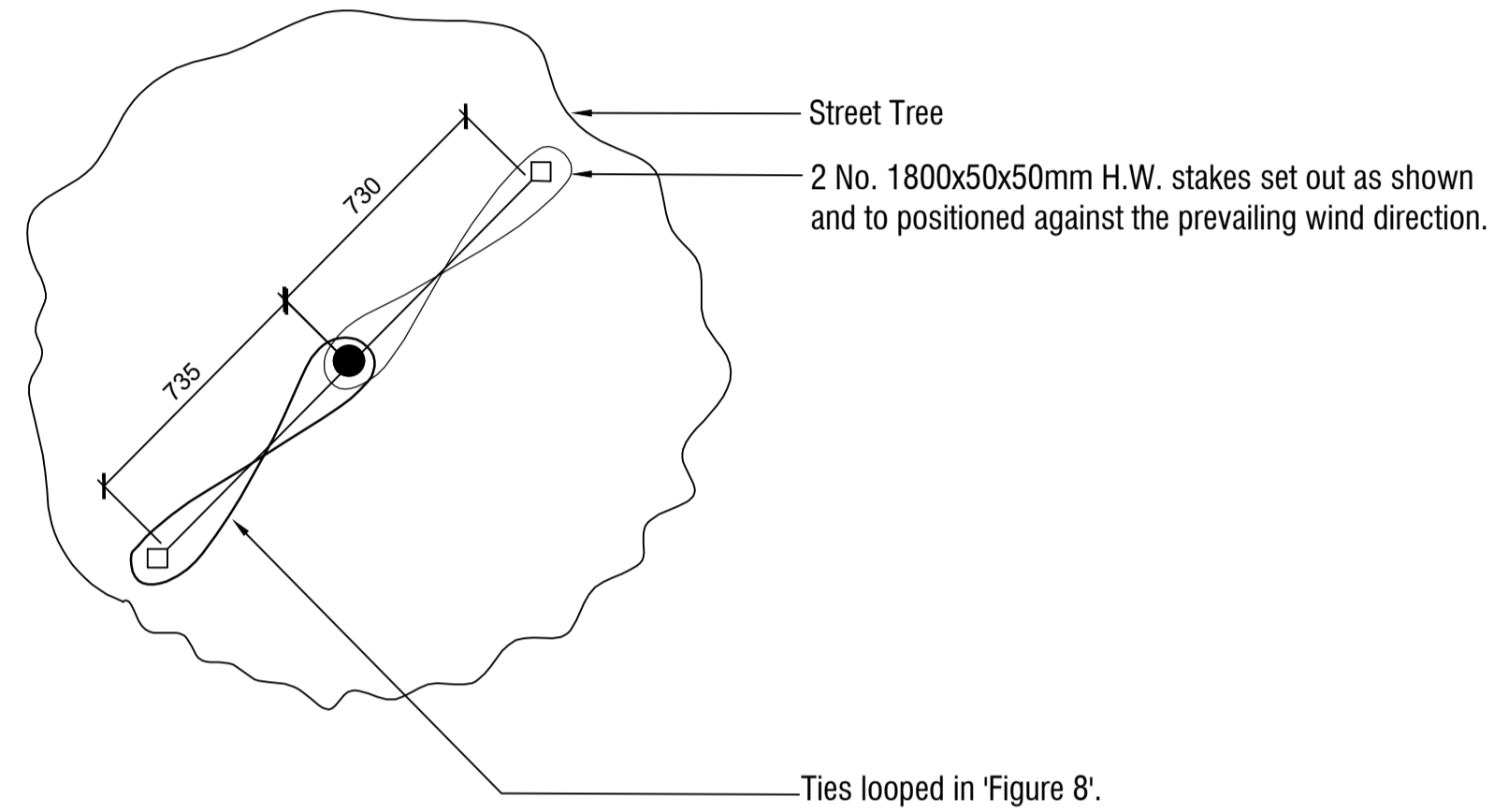

**1 SEMI-ADVANCED TREE PLANTING DETAIL (HUME CITY COUNCIL STANDARD DETAIL)**  
NTS

NOTE: Garden beds to be crowned towards centre of garden bed - minimum 1:50 slope.

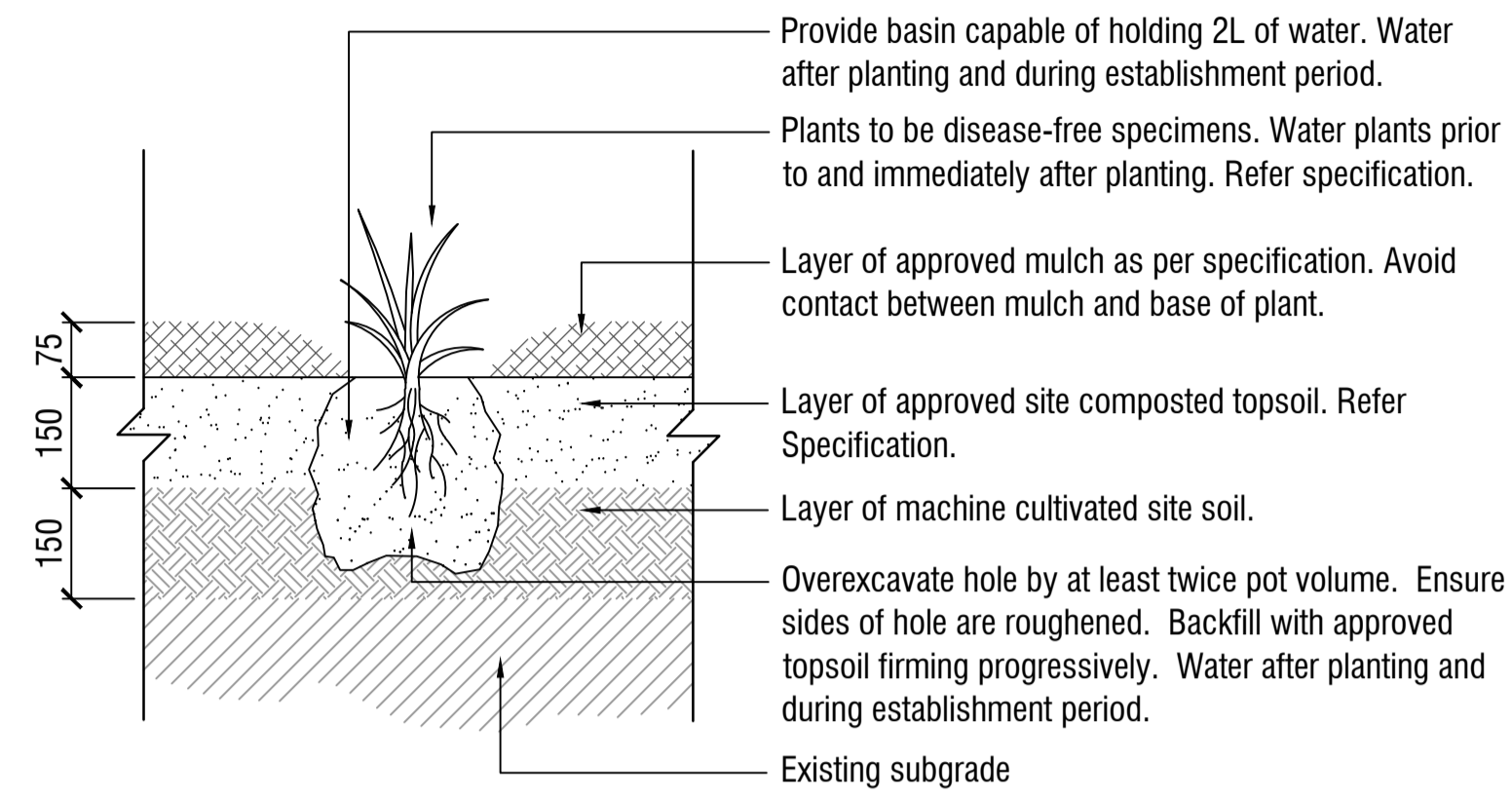

**2 GARDEN BED PLANTING**  
Scale 1:10 @ A1

Unless otherwise noted, spade edge between all grass and garden bed areas.

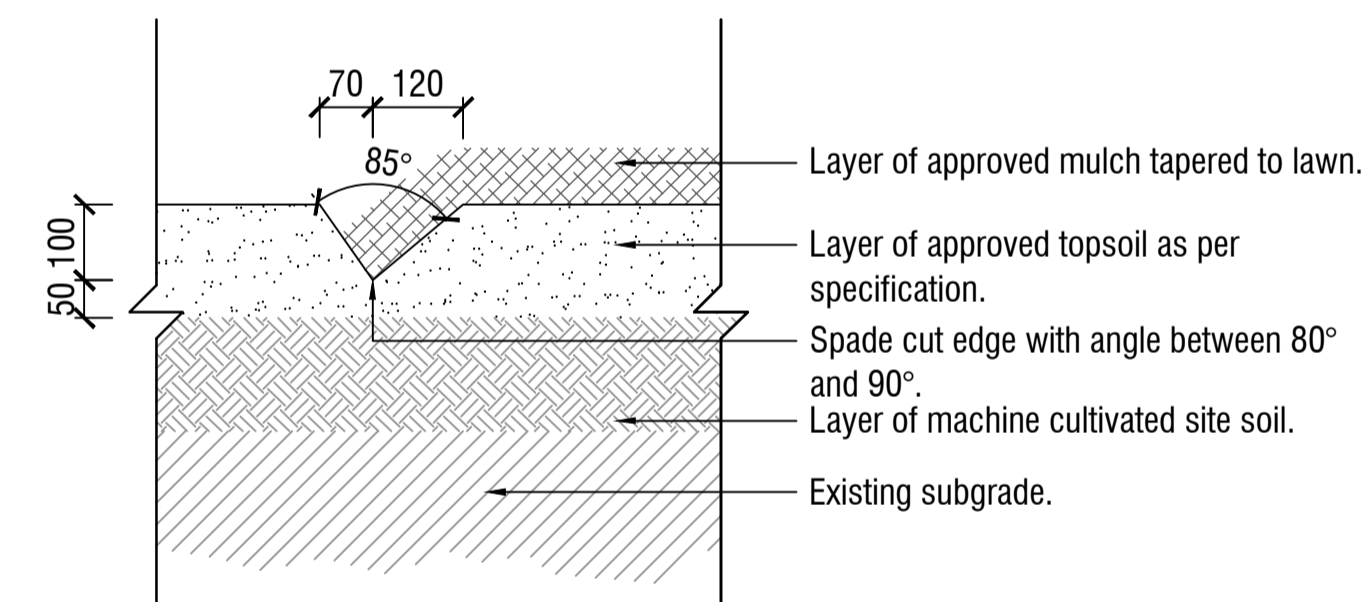

**3 SPADE EDGE**  
Scale 1:10 @ A1

- NOTES
- Existing pasture grass and/or weeds are to be sprayed with herbicide.
  - No machinery to be used within the drip line of existing trees.
  - Topsoil to be raked to a fine tilth, removal of all surface rocks, large lumps of clay, weeds and rubbish prior to application of turf to all areas as shown.
  - New grassed areas to be protected from trespass and traffic with star pickets and barrier rope until grass is established.

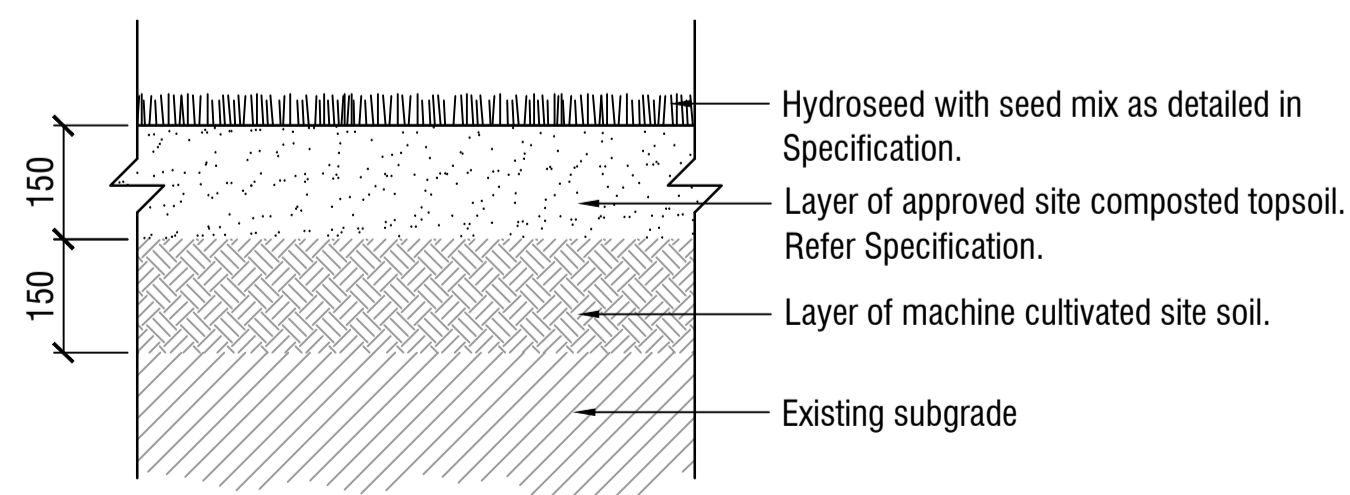

**4 HYDROSEED GRASS DETAIL - STREETSCAPE**  
Scale 1:10 @ A1

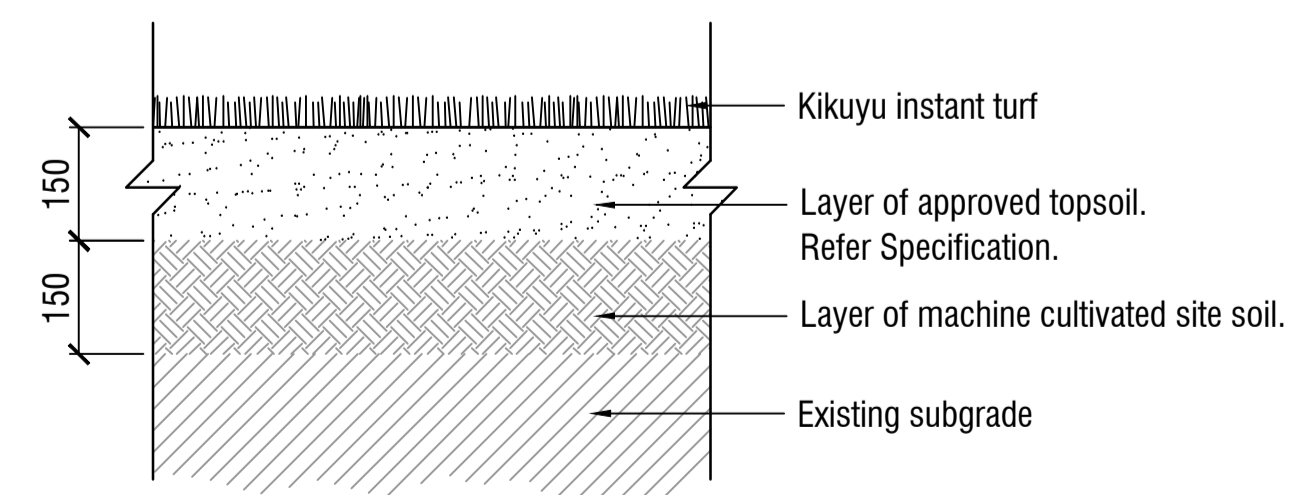

**5 INSTANT TURF GRASS DETAIL - RESERVE**  
Scale 1:10 @ A1

**NOTES**

**spiire**

© Spiire Australia Pty Ltd All Rights Reserved  
This document is produced by Spiire Australia Pty Ltd solely for the benefit of and use by the client in accordance with the terms of the retainer. Spiire Australia Pty Ltd does not and shall not assume any responsibility or liability whatsoever to any third party arising out of any use or reliance by third party on the content of this document.

L6 414 LA TROBE STREET PO BOX 16084 MELBOURNE  
VICTORIA 8007 AUSTRALIA T 61 3 9993 7888  
www.spiire.com.au ABN 55 050 029 635

**PRELIMINARY**

REV	DESCRIPTION	APP	DATE
F	ISSUED FOR CONSTRUCTION	MB	07/07/22
E	ISSUED FOR APPROVAL	MB	05/07/22
D	ISSUED FOR APPROVAL	MB	27/06/22
C	ISSUED FOR APPROVAL	MB	21/06/22
B	ISSUED FOR APPROVAL	MB	21/04/22
A	PRELIMINARY ISSUE	MB	10/01/22

**TRIJENA**  
**STAGE 15 STREETSCAPES**

**DETAILED DESIGN**  
**DETAILS - SHEET 1**  
**SHEET 4 OF 4**  
**HUME CITY COUNCIL**  
**PGG(MICKLEHAM) PTY LTD**

**AS SHOWN**

DESIGNED	DRAWN	CHECKED	APPROVED
BM	BM	GV	MB
DATE	DRG NO.	REV	
10/01/2022	304018LD900	F	